

## Clutch & brake DC to DC type / DC to AC type

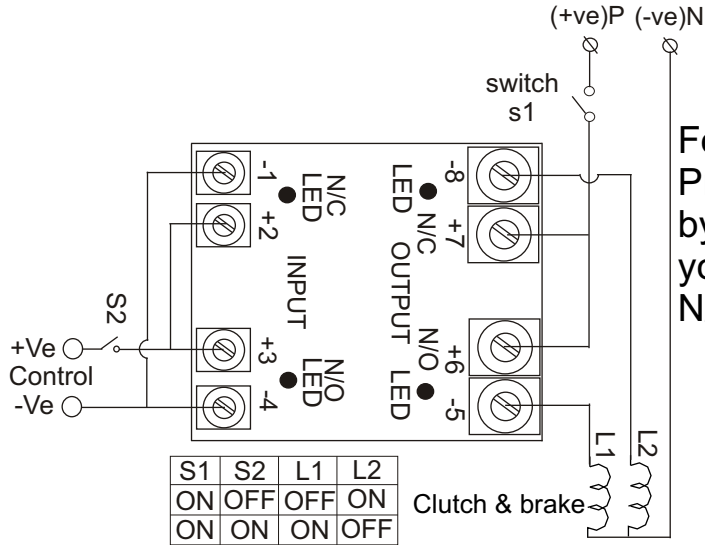

For clutch and brake control by Proximity Switch Or Tab Switch by N/O & N/C Solid State Relay you have to put delay of 20ms from N/O to N/C operation or vice versa

For clutch and brake control by PLC

1. You need two nos of DC to DC - N/O. Type SSR  
704 PMDD 200 05 00
2. POWER MOSFET MODELS- 704 PMDD 200 05 00 or  
MODEL 701PMDD200 15 00 or MODEL 708PMDD200 08 00 can be used
3. To Program delay of 20mS from Clutch ON to Clutch OFF, Delay of 20mS from Brake OFF to Brake ON & again 20mS delay from Clutch OFF to Clutch ON